



Harmonization of Systems and Software Engineering Processes

For 2006 Systems & Software Technology Conference

James W. Moore, CSDP, F-IEEE
The MITRE Corporation
moorej@mitre.org
1.703.983.7396

1 April 2006

The author's affiliation with The MITRE Corporation is provided for identification purposes only, and is not intended to convey or imply MITRE's concurrence with, or support for, the positions, opinions, or viewpoints expressed by the author.

What are Standards Good For?

A standard is a Name for an otherwise fuzzy concept

In a complex, multidimensional trade space of solutions ...

... a standard gives a name to a bounded region.

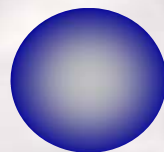

It defines some characteristics that a buyer can count on.

- **Some standards assign names to practices or collections of practices.**
- **This enables communication between**
 - **Buyer and seller**
 - **Government and industry**
 - **Insurer and insured**



15288 and 12207 Give “Names” to Processes

- **ISO/IEC 15288:2002 gives names to processes in the life cycle of a system.**
- **ISO/IEC 12207:1995 gives names to processes in the life cycle of a software product or service.**
- **The names are important so that acquirers and suppliers can communicate regarding their practices.**
 - **“Oh, when you say ‘implementation’, you include ‘testing’? No, no, no, that’s a separate thing; our contract doesn’t include that!”**
- **The names are important to provide a context for implementing *improved practices*.**
- **The names are important as a basis for process evaluation and improvement, e.g. CMMI.**

Key Standards for Software and System Processes

- **ISO/IEC 15288, System Life Cycle Processes**
 - 25 processes spanning the life cycle of a system.
 - The standard is primarily descriptive.
- **ISO/IEC 12207:1995, Software Life Cycle Processes**
 - 17 processes spanning the life cycle of a software product or service.
 - The standard is somewhat prescriptive in defining a minimum level of responsible practice.
 - Describes processes meeting the needs of organizational process definition.
- **ISO/IEC 12207:Amd 1 and Amd 2**
 - Redescribes processes to meet the needs of process assessment and improvement.



Harmonization of 15288 and 12207

- Both standards were technically excellent.
- The standards were difficult to use together because of some differing concepts.
- Furthermore, a set of amendments to 12207 (for the process assessment community) compounded the difficulty by adding some additional differing concepts.
- A project is underway to “harmonize” the standards.

Differing Architectural Constructs

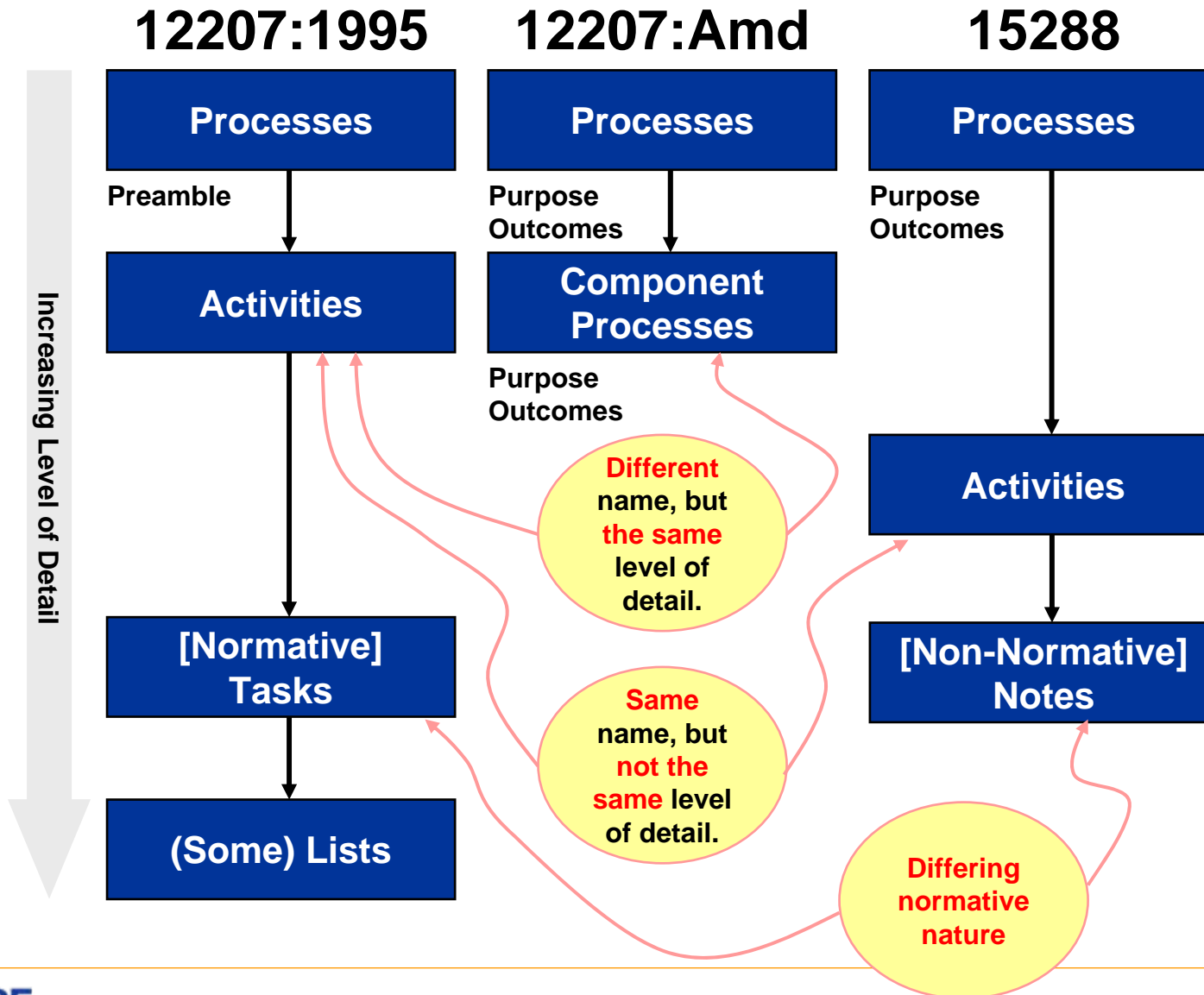

The Harmonization Problem



Starting with a diverse set of standards with ...

- Different terms
- Different process sets
- Different process architectures
- Different levels of prescription
- Different audiences*

... develop a revised set of standards with ...

- A single vocabulary
- A single process set
- A single, uniform architecture
- A shared level of prescription
- Suitable across the audiences

... all without needlessly disrupting current organizational investment based on usage of the current set of standards.

* Systems versus software and process definition versus process assessment



Status of Harmonization

- Project to solve the problem in “one swell foop” had made little progress in two years.
- In May 2005, IEEE Computer Society made a proposal for Harmonization “Lite”.
 - Perform enough harmonization to achieve most of the benefits.
 - Emphasize “alignment” of the standards, rather than complete “integration”.
 - Focus on interoperability of the standards.
- ISO/IEC JTC 1/SC 7/WG 7 accepted the proposal and formulated a two-phase plan:
 - Phase 1, *Alignment*: Structural refactoring, emphasizing backward compatibility
 - Phase 2, *Integration*: Full integration of processes

The Harmonization Problem – Problems addressed in the Alignment Phase

Starting with a diverse set of standards with ...

- Different terms
- Different process sets
- Different process architectures
- Different levels of prescription
- Different audiences

... develop a revised set of standards with ...

- A single vocabulary
- A single process set
- A single, uniform architecture
- A shared level of prescription
- Suitable across the audiences



... all without needlessly disrupting current organizational investment based on usage of the current set of standards.

* System versus software and process definition versus process assessment

Intended Relationships of Key Software Engineering Process Standards

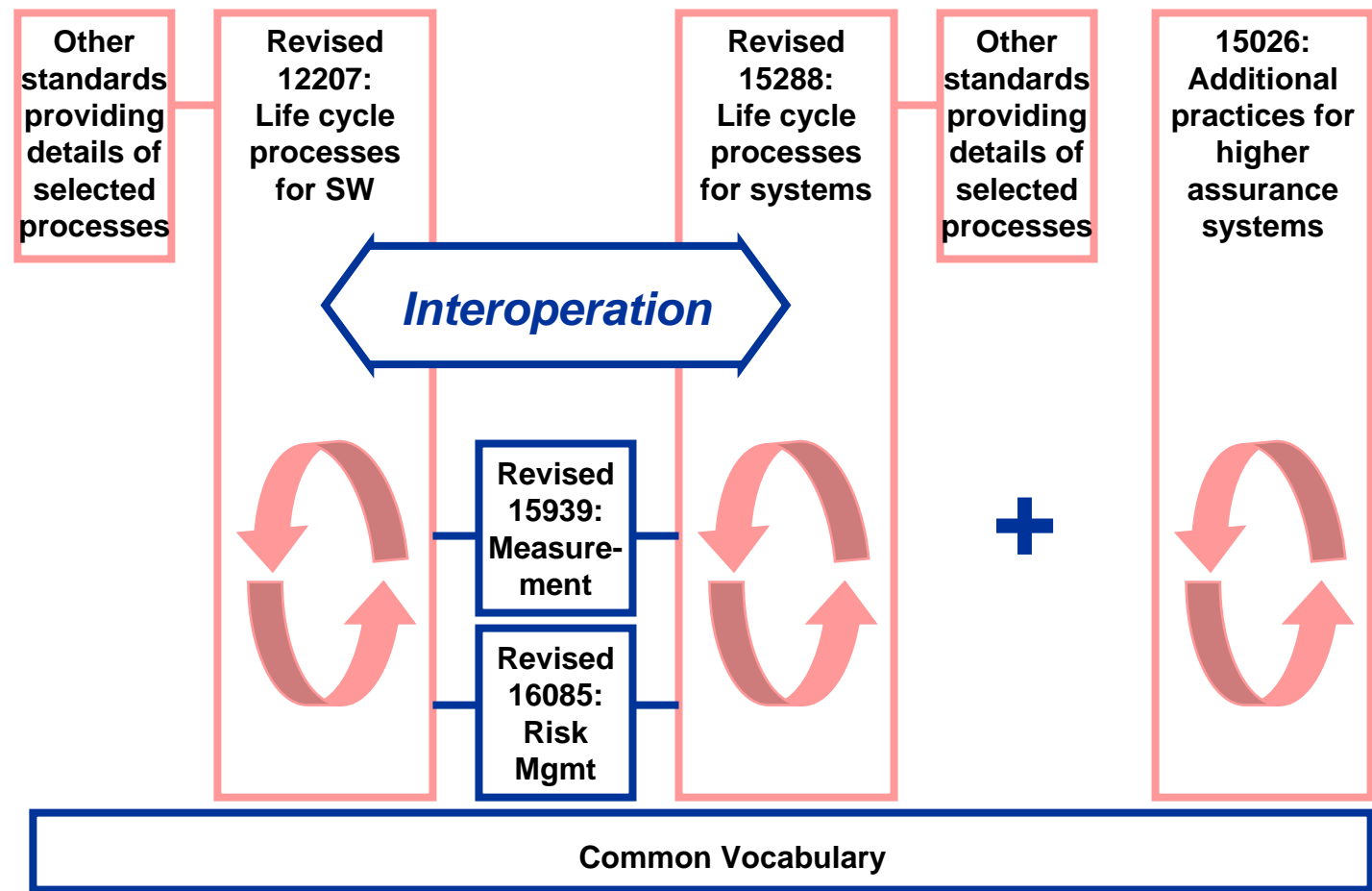



Key Terminology and Concepts

- **Organization:** a group of people and facilities with an arrangement of responsibilities, authorities and relationships
 - A part of an organization is an organization if it meets the definition.
 - An *individual* can be an organization if s/he meets the definition.
- **Party:** an organization, entering into an agreement
- **Project:** an endeavor with defined start and finish dates to create a product or service in accordance with specified resources and requirements

Key Terminology and Concepts

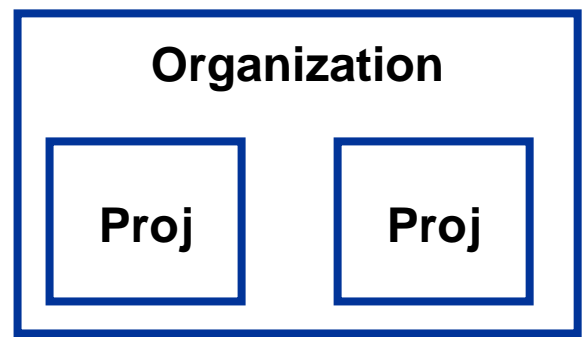
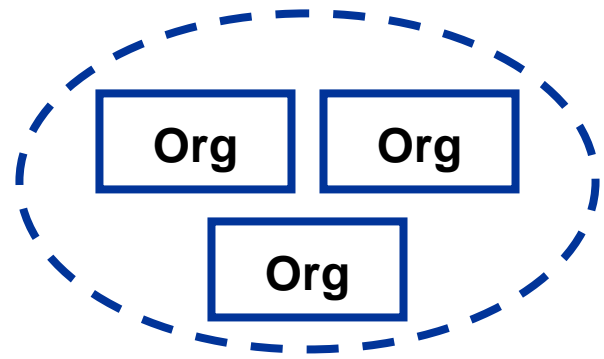
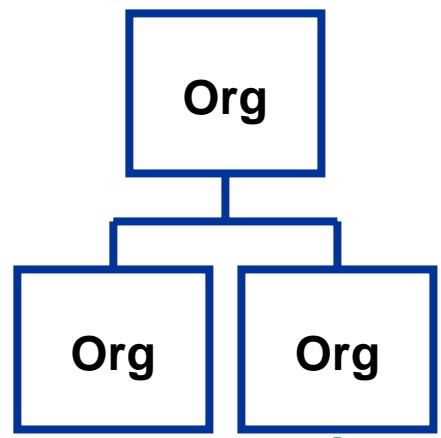

Organizations can collaborate to make larger organizations.

Organizations conduct projects to do things, notably to deal with systems.

An individual can be an organization



Organizations make agreements to acquire and supply products and services.



Agreeing organizations are called parties.

Key Terminology and Concepts

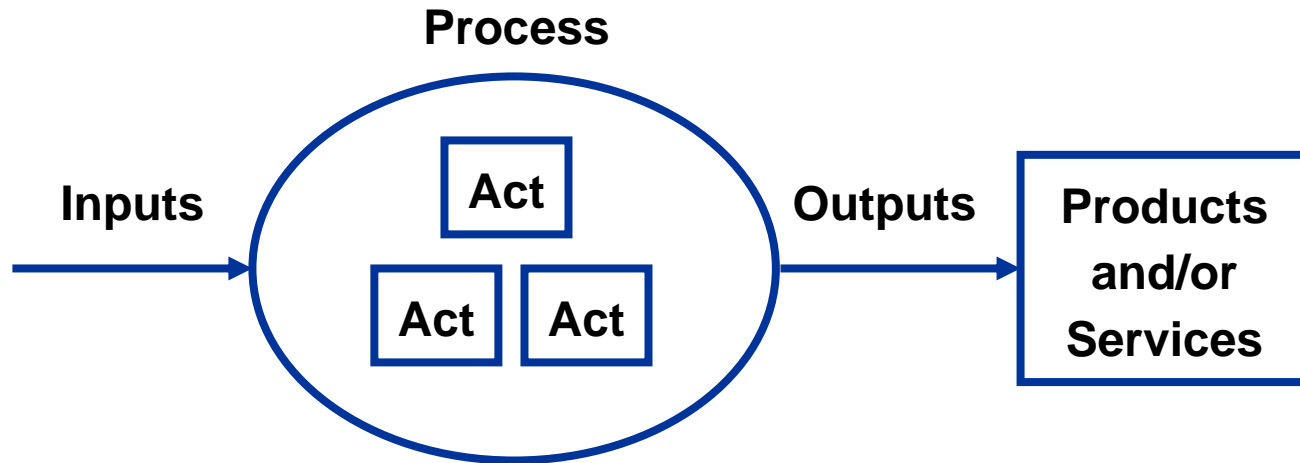

- **Process:** a set of interrelated or interacting *activities* which transforms inputs into outputs
- **Product:** the result of a process
- **Service:** performance of activities, work, or duties associated with a product

Key Terminology and Concepts

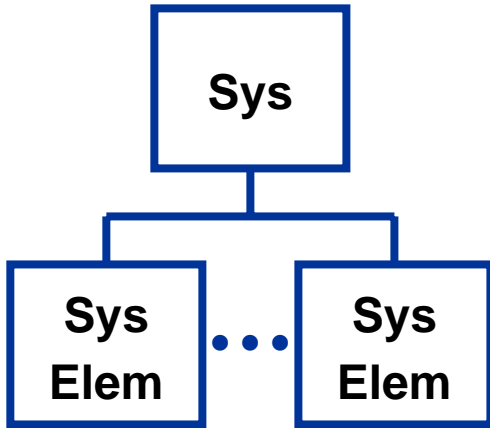

A *system* is composed of *system elements*. Each element is *implemented* and then *integrated* into the system. One invocation of 15288 suffices to create a system composed of a set of elements.

However, 15288 states that a system element can itself be regarded as a system. So, 15288 can be invoked hierarchically to create a hierarchy of systems and their elements. A hierarchy of systems often implies a hierarchy of projects.

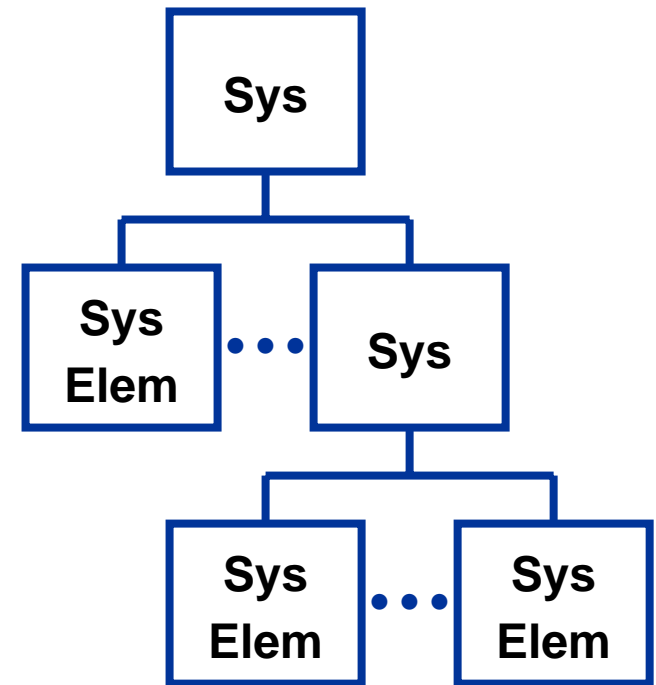

Key Terminology and Concepts

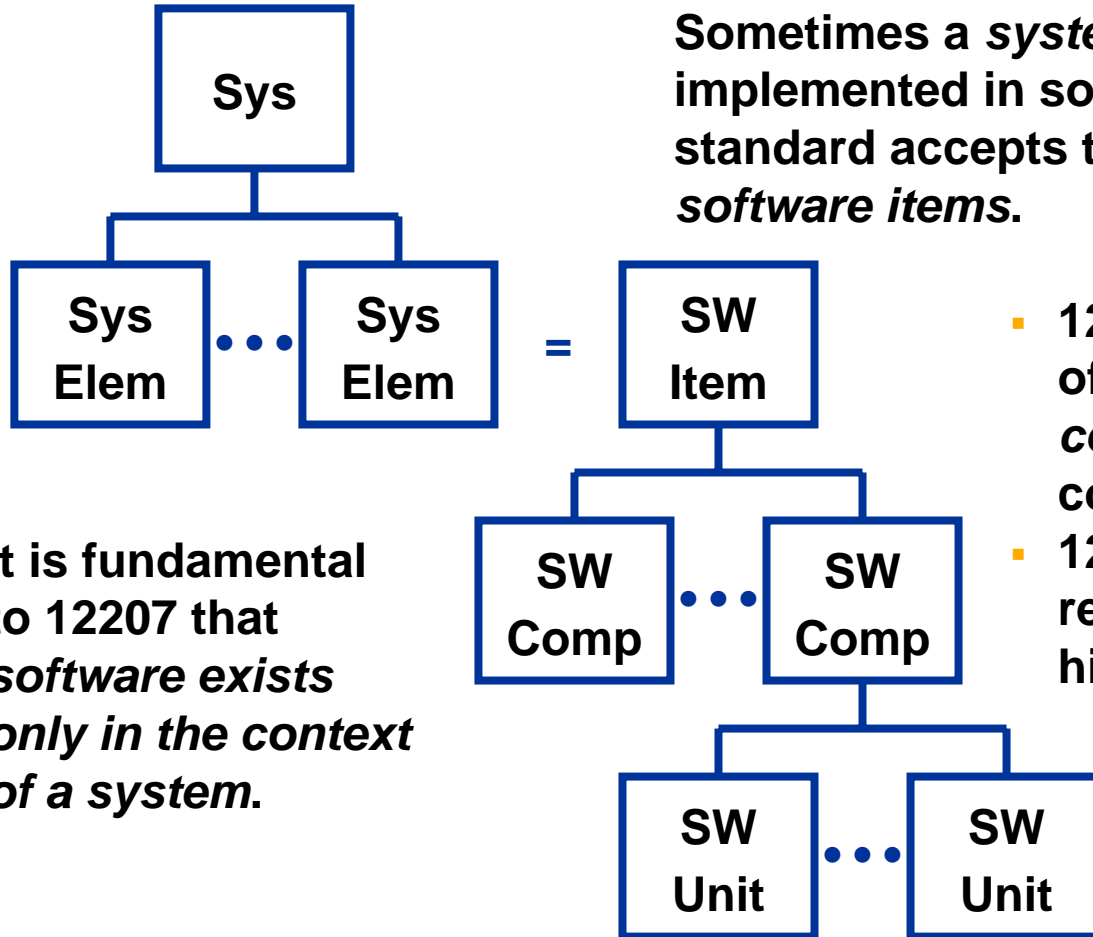

Sometimes a *system element* is to be implemented in software. The 12207 standard accepts this as one or more *software items*.

It is fundamental to 12207 that *software exists only in the context of a system*.

- 12207 uses a hierarchy of *items* – composed of *components* – composed of *units*.
- 12207 is *not* invoked recursively to create this hierarchy.

Key Terminology

- Every *system* has a *life cycle* which is viewed as composed of *stages*. (The standards do not require a particular set of stages.)
 - Each stage has a purpose and makes a contribution to the life cycle.
- *Stages* are initiated and terminated by *decision gates*.
- Stages may overlap and may be concurrent.
- The purpose of each stage is accomplished by executing *processes*.
- Any *process* may be useful in any stage.

← This is important.



A typical set of life cycle stages

- It is a common error to talk about life cycle stages when one really means processes or vice-versa.
- Locating practices with respect to processes provides much greater precision.

Converged Architecture

Purpose: a short description of intent

Outcomes: a list of things to be achieved

Activities: a list of things to be done

Tasks: specific “shall”, “should”, “may” items

Notes: helpful information

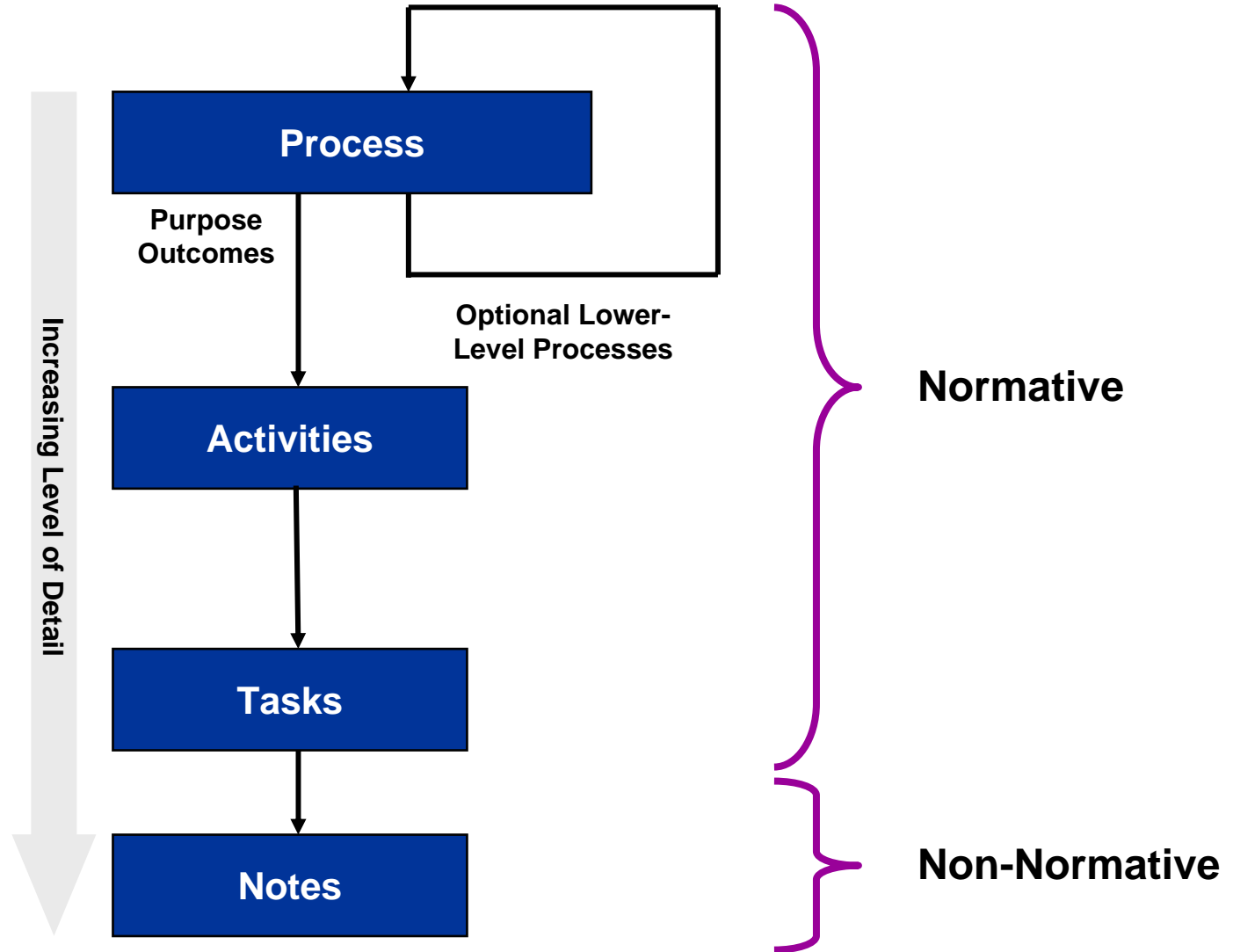



Relationship of 15288 and 12207

- Both contain process models that are nearly identical:
 - The differences are rational rather than accidental.
- 15288 describes the processes at the system level.
- 12207 specializes the same processes to software, and adds processes specific to software.

To deal with a system use 15288
To deal with a software element of a system...	... use 15288 and the software processes of 12207
To deal with a software product or service (with minimal surrounding system) use 12207

Process Model of 15288 and 12207

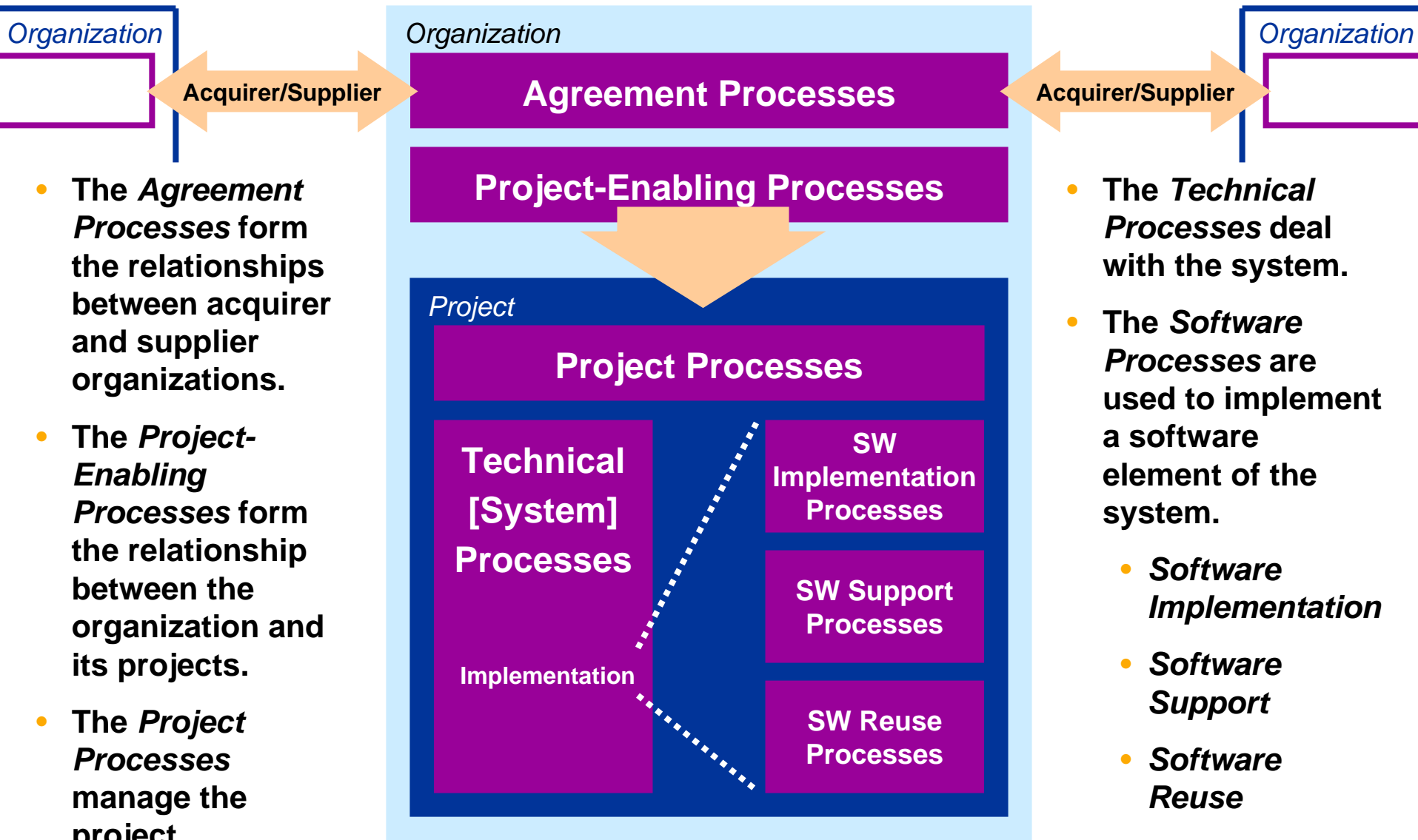

- The **Agreement Processes** form the relationships between acquirer and supplier organizations.
- The **Project-Enabling Processes** form the relationship between the organization and its projects.
- The **Project Processes** manage the project.

- The **Technical Processes** deal with the system.
- The **Software Processes** are used to implement a software element of the system.
 - **Software Implementation**
 - **Software Support**
 - **Software Reuse**

Agreement Processes

Activities of the Acquisition Process	Activities of the Supply Process
Prepare acquisition	
Advertise acquisition	Supplier tendering
Supplier selection	
Contract agreement	Contract agreement
Supplier monitoring	Contract execution
Acquirer acceptance	Product/service delivery
Closure	Closure

- **Two Agreement Processes:**
 - *Acquisition*
 - *Supply*
- The activities of the two processes “talk to” each other.
- 12207 is specialized to software and is more prescriptive.

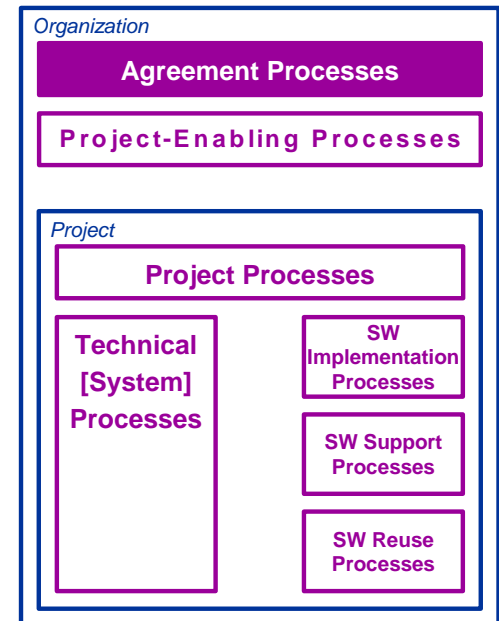

Organization Project-Enabling “Processes”

- There are issues of scope and competency when system and software engineers try to define organizational processes. Therefore, these are really resource dependencies rather than complete process definitions.
- The dependencies may be grouped by subject area.
- “Processes”:
 - Life Cycle Model and Process Management
 - Infrastructure Management
 - System Portfolio Management
 - Human Resource Management
 - Quality Management
- 12207 is more prescriptive and specializes the processes to software.

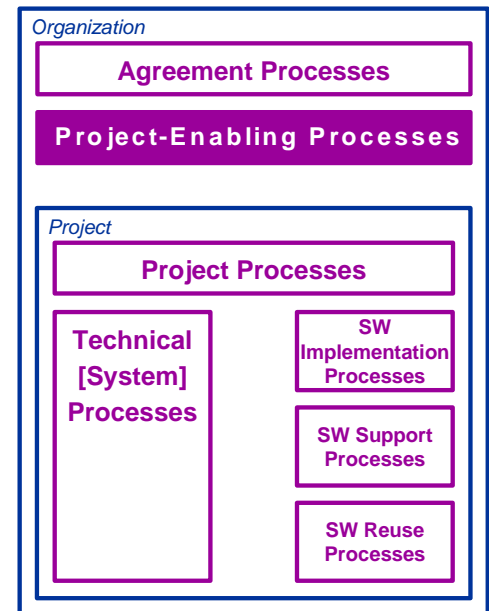

Project Processes

Endangered!

- Two categories:
 - Project Management Processes (similar to PMBOK “process groups”):
 - *Project Planning, Project Execution, Project Assessment and Control*
 - Project Support Processes (similar to selected PMBOK “knowledge areas”):
 - *Decision Management, Risk Management, Configuration Management, Information Management, Measurement*

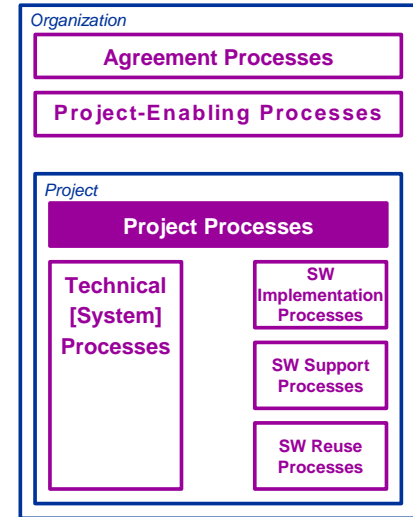

- 15288 and 12207 have nearly identical processes in this area.
- 12207 is more prescriptive re software project plans.

Process Groups / Knowledge Area	Initiating	Planning	Executing	Controlling	Closing
4. Project Integration Management		4.1 Project Plan Development	4.2 Project Plan Execution	4.3 Integrated Change Control	
5. Project Scope Management	5.1 Initiation	5.2 Scope Planning 5.3 Scope Definition		5.4 Scope Verification 5.5 Scope Change Control	
6. Project Time Management		6.1 Activity Definition 6.2 Activity Sequencing 6.3 Activity Duration Estimating 6.4 Schedule Development		6.5 Schedule Control	
7. Project Cost Management		7.1 Resource Planning 7.2 Cost Estimating 7.3 Cost Budgeting		7.4 Cost Control	
8. Project Quality Management		8.1 Quality Planning	8.2 Quality Assurance	8.3 Quality Control	



15288 Technical Processes

- Stakeholder Requirements Definition
- Requirements Analysis
- Architectural Design
- Implementation
 - Example: Implementation of a Sub-system
 - Example: Implementation of a Software Element
 - Example: Implementation of a Hardware Element
- Integration
- Verification
 - Center of gravity is “after-the-fact” verification that the integrated system achieves its requirements.
- Transition
- Validation
 - Center of gravity is “after-the-fact” evaluation that the completed system meets user needs.
- Operation
- Maintenance
- Disposal

Some see a “V Model” in this set of processes.

Connection to Software LCP

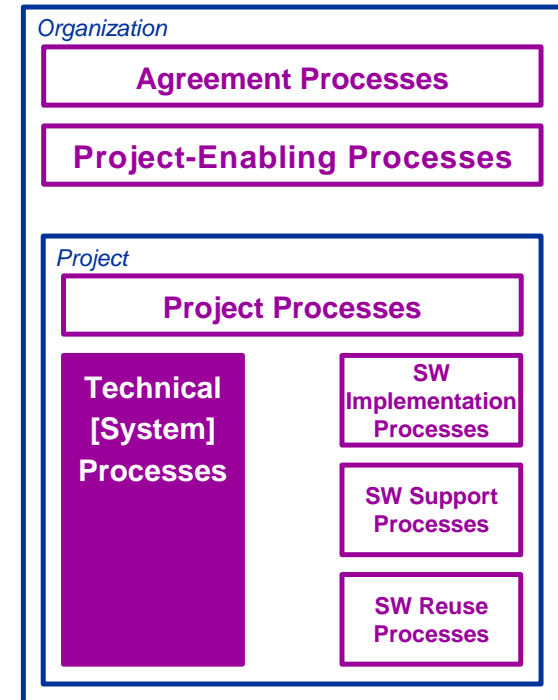



Correspondence of Technical Processes of 15288 and 12207

15288	12207	Relationship
Stakeholder Requirements Definition	System Requirements Elicitation	Nearly identical.
Requirements Analysis	System Requirements Analysis	More prescriptive and specialized
Architectural Design	System Architectural Design	More prescriptive and specialized
Implementation	Implementation	More prescriptive and specialized
Integration	System Integration	More prescriptive and specialized
Verification	System Qualification Testing	Contributes to the outcomes
Transition	Software Installation <i>and</i> Software Acceptance Support	Contribute to the outcomes
Validation		(Performed by another process.)
Operation	Software Operation	More prescriptive and specialized
Maintenance	Software Maintenance	More prescriptive and specialized
Disposal	Software Disposal	More prescriptive and specialized

Software Implementation Processes

Connection to System LCP

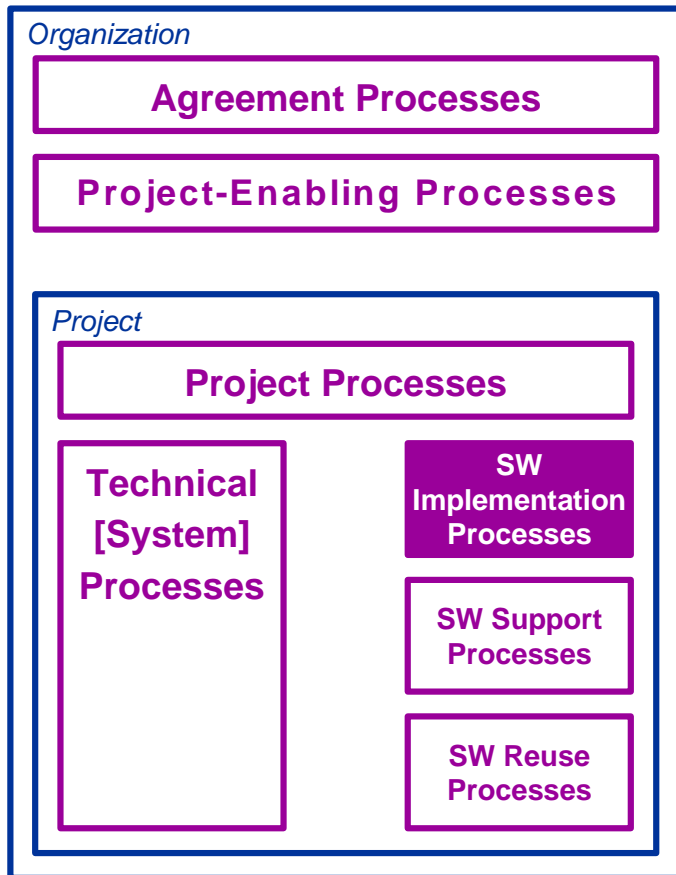

- **Software Implementation** is a specialization of System Implementation. It contains some lower-level processes distinct to software development.
 - Software Requirements Analysis
 - (Option to use 15288 process instead.)
 - Software Architectural Design
 - (Option to use 15288 process instead.)
 - Software Detailed Design
 - Software Coding and Testing
 - Software Integration
 - Software Qualification Testing
 - (Option to use 15288 process instead.)

Software Support Processes

- **Software Documentation**
 - Focused on SW life cycle artifacts
- **Software Configuration Management Process**
 - Specialized to SW
- **Software Quality Assurance Process**
 - Specialized to SW
- **Software Verification Process**
 - Center of gravity is continuous verification
- **Software Validation Process**
 - Center of gravity is continuous validation
- **Software Review Process**
- **Software Audit Process**
- **Software Problem Resolution Process**

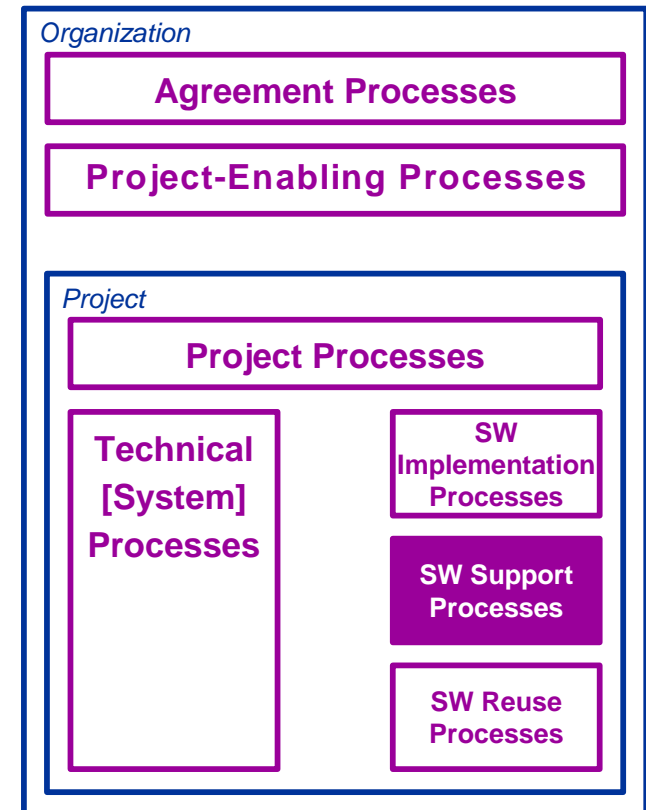

Software Reuse Processes

- **Software Reuse Processes**
 - Domain Engineering
 - Reuse Asset Management
 - Reuse Program Management
- **These are grouped separately because**
 - They inherently cut across project boundaries.
 - But, they don't seem to be “enterprise” level processes.
 - They are sort of a “loose end”.
- **Ultimately, these may be treated as a special kind of project.**

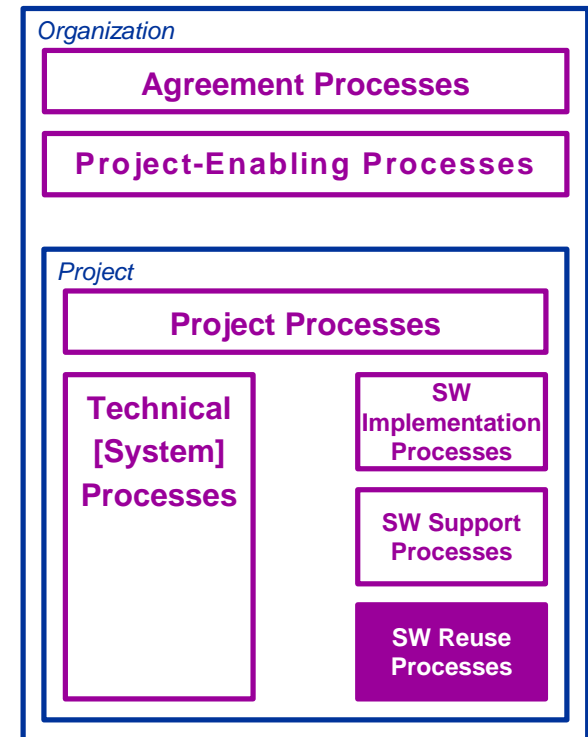

Intended Relationships of Key Software Engineering Process Standards

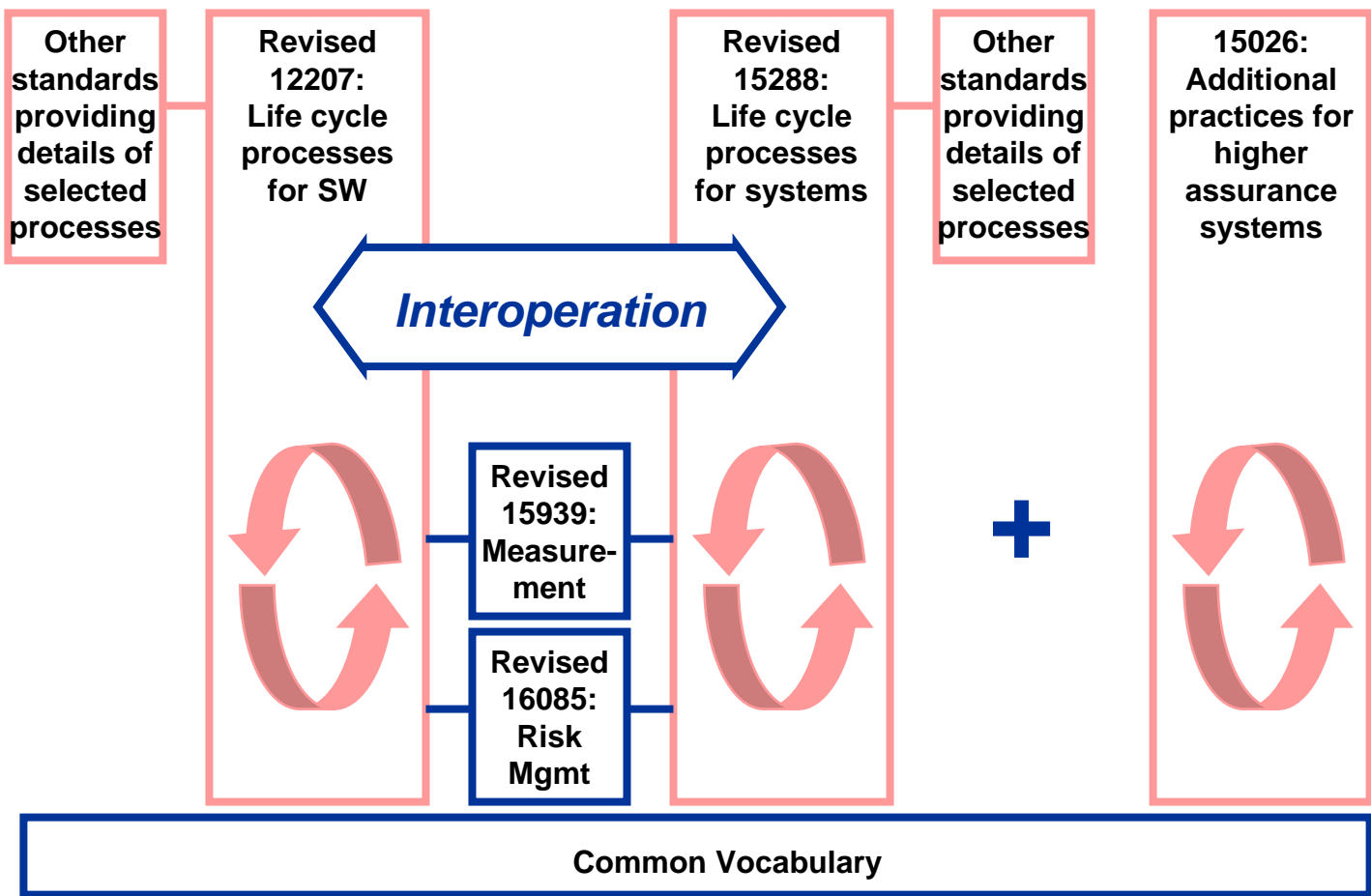



Measurement process

- **ISO/IEC JTC 1/SC 7 has a single standard for a generic software measurement process:**
 - **ISO/IEC 15939, Software Measurement Process**
- **It is currently being generalized to the systems level – only trivial changes are required.**
- **It adds detailed requirements and helpful guidance to the measurement provisions of ISO/IEC 15288 and ISO/IEC 12207.**
- **It provides a process framework for making measurements of software and systems under development and completed software and system products.**
- **It provides a single “measurement information model” for describing measurement activities.**

Overview of Measurement Process provided by ISO/IEC 15939

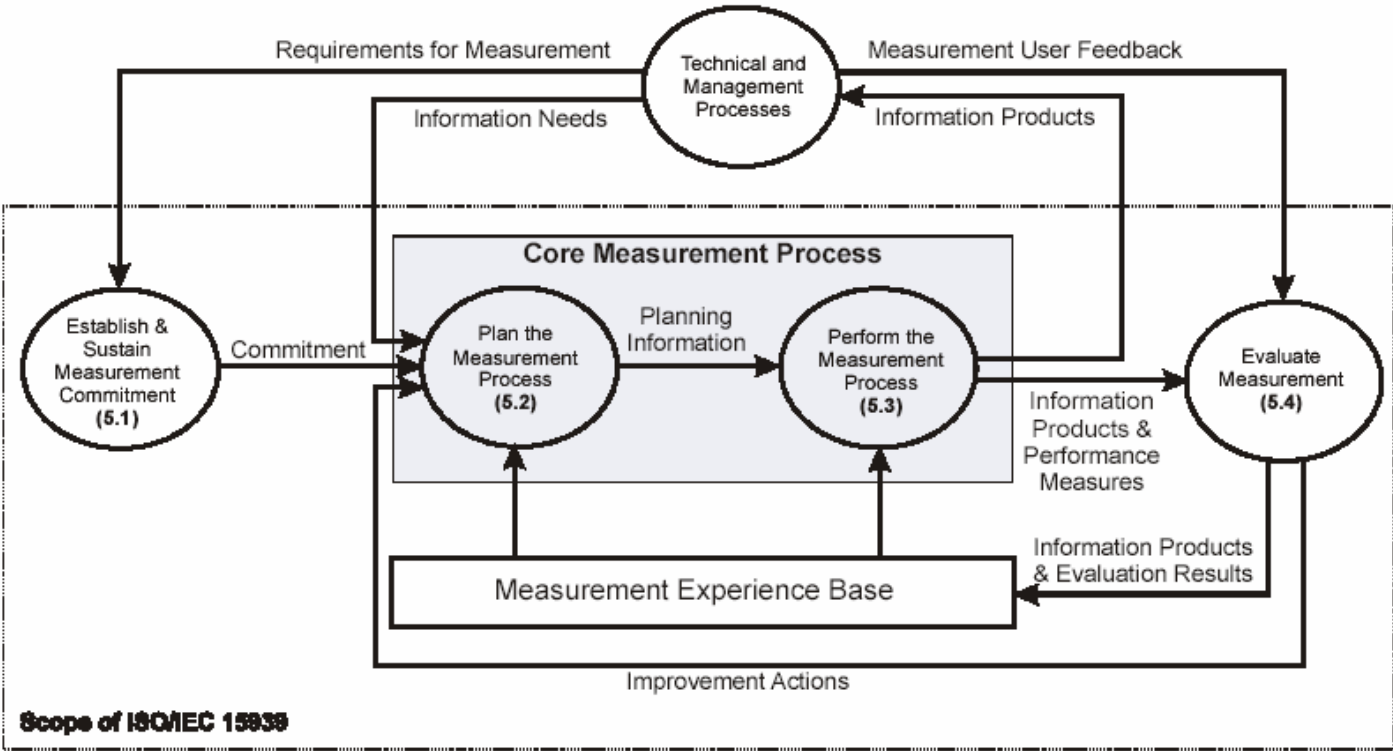

Scope of ISO/IEC 15939



From ISO/IEC 15939

Measurement Information Model of ISO/IEC 15939

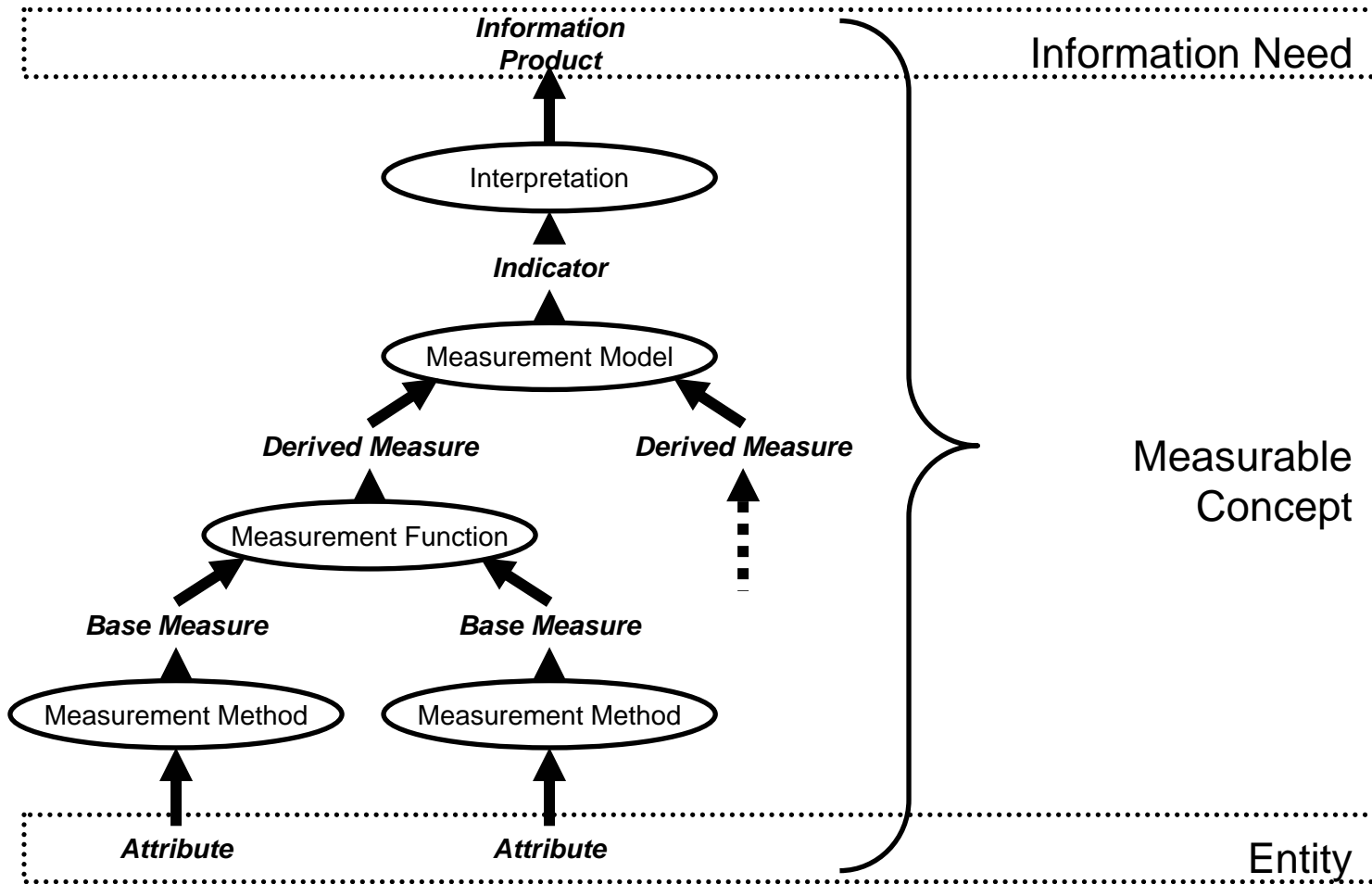

Status:
 Currently being revised to address system as well as software. Only minor changes are needed.

From James W. Moore, *Road Map to Software Engineering: A Standards-Based Guide*, 2006, John Wiley and Sons



Risk Management Process

- **ISO/IEC JTC 1/SC 7 has a single standard for a generic risk management process:**
 - **ISO/IEC 16085, Software Risk Management**
- **It is currently being generalized to the systems level – only trivial changes are required.**
- **It adds detailed requirements and helpful guidance to the risk management provisions of ISO/IEC 15288 and ISO/IEC 12207.**
- **It provides a process framework for managing risk – programmatic, technical and operational – throughout the life cycle of software and systems.**
- **It is completely consistent with the risk management vocabulary of ISO Guide 73 – recently produced by ISO TMB.**

Risk Management Process of ISO/IEC 16085

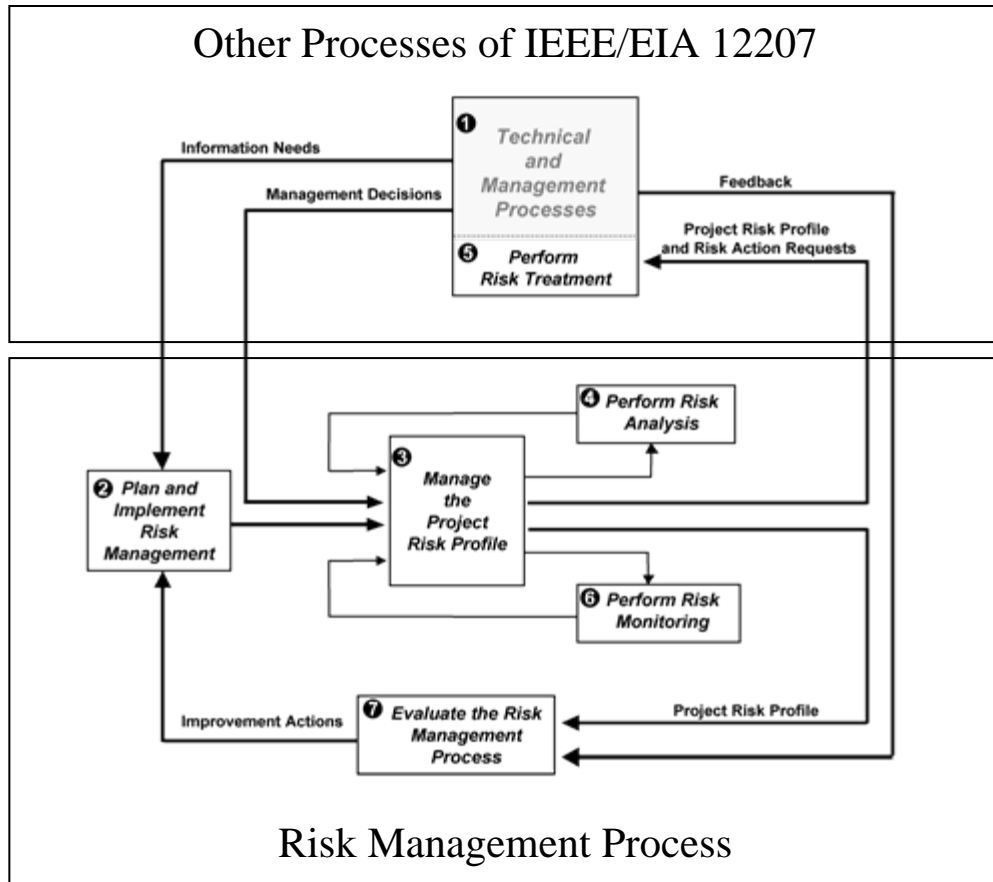

From IEEE Std 1540-2001, page 6, ©IEEE, 2001, used permission

Status:

The standard is now undergoing small modifications to make it applicable to system life cycle processes as well as software.



Assurance Activities

- **ISO/IEC JTC 1/SC 7 plans a single standard for a generic software assurance activities:**
 - **ISO/IEC 15026:200x, Systems and Software Assurance**
- **The planned standard is a major revision of the current standard describing “integrity levels”.**
- **Using a baseline of the life cycle processes of ISO/IEC 15288 and ISO/IEC 12207, it will provide additional activities used to assure the existence of critical properties such as safety and security.**
- **SC 7 hopes to harmonize the standard with IEC TC 56 (dependability), IEC TC 65 (safety), and SC 27 (security).**

Relationship of 15026 to life cycle process standards

The revision of ISO/IEC 15026 will incorporate the concept of an “assurance case” (a generalization of safety case) as a life-cycle artifact justifying confidence that a system has a desired critical property.

Because the case is a life-cycle artifact, it would be maintained and revised during maintenance and operation of the system.

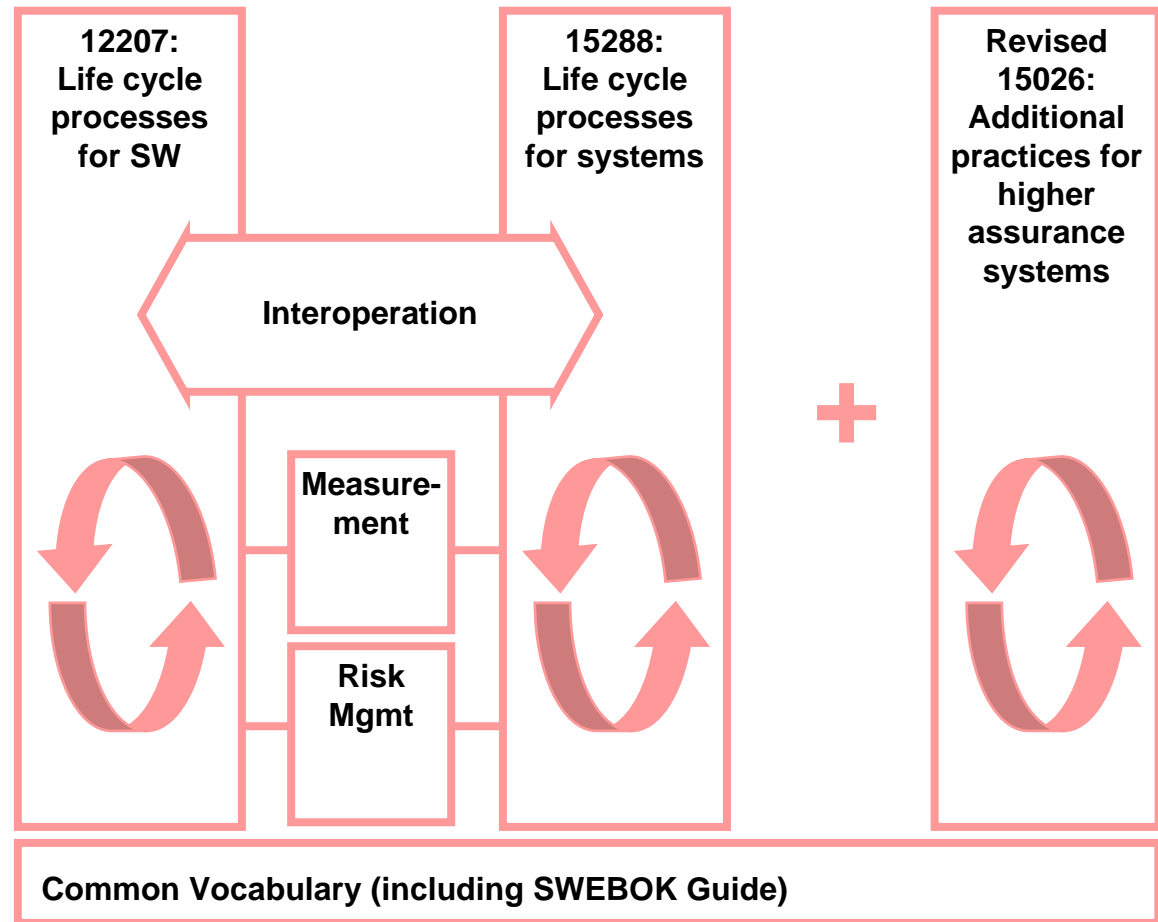



1 TECHNICAL & MANAGEMENT PROCESSES

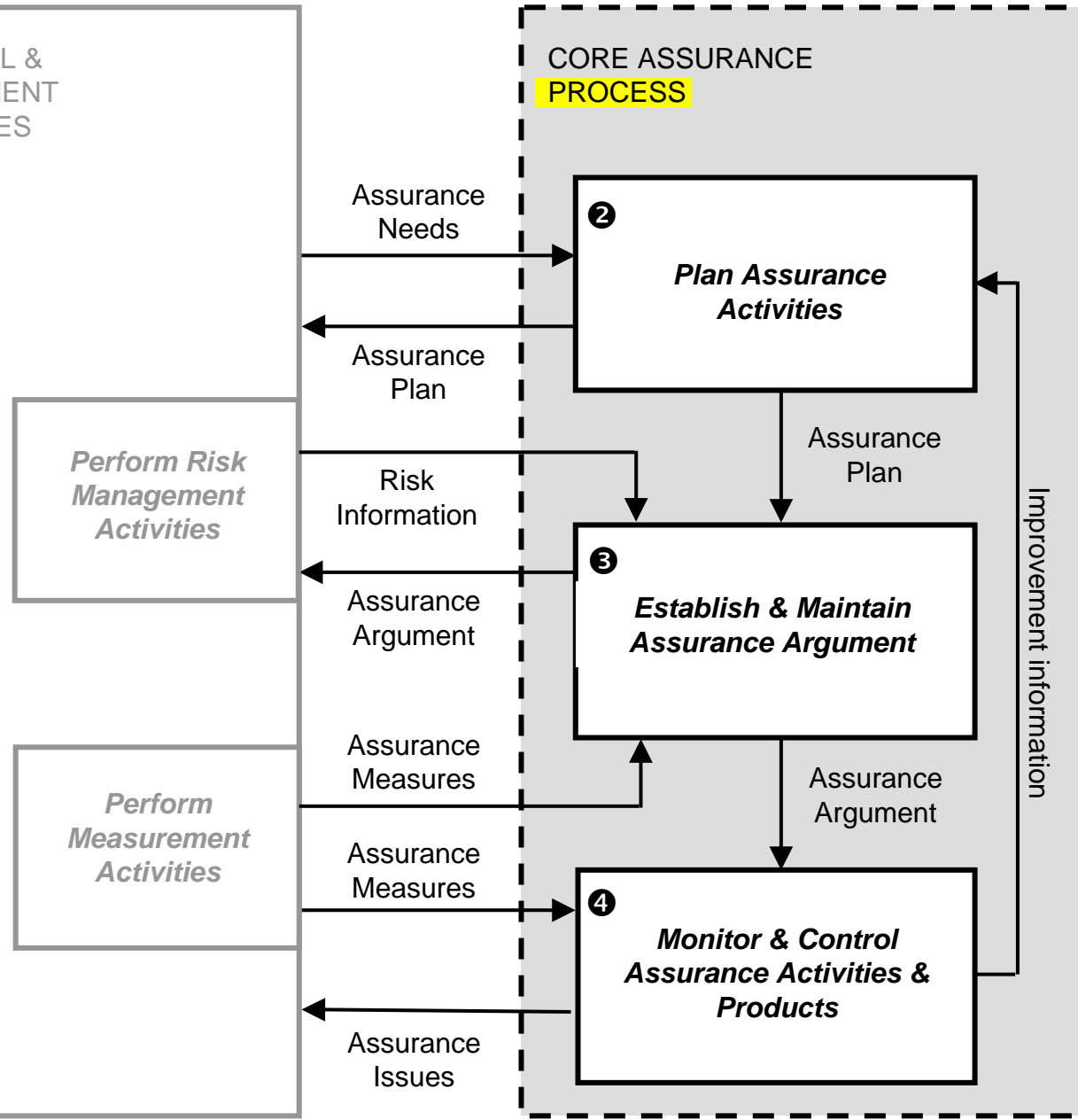

Status:

Currently being drafted.

Providing a distinct “process” for assurance is an issue.

Taken from a chart by Paul Croll

Status of Revisions

- In May 2005, IEEE Computer Society made a proposal for Harmonization “Lite”.
 - Revise SW and Systems LC standards for better fit, providing a baseline of processes for use by other standards.
 - Focus on interoperability of the standards.
- ISO/IEC JTC 1/SC 7/WG 7 accepted the proposal and formulated a two-phase plan:
 - Phase 1, *Alignment*: Structural refactoring, emphasizing backward compatibility
 - Phase 2, *Integration*: Full integration of processes
- Phase 1 is underway
 - January 2006: Working Drafts out for review
 - June 2006: Formal balloting begins
 - ca June 2007: Publication



Moving Forward

- **One two-person team is preparing the short-term alignment revision of ISO/IEC 12207. Second working draft has been distributed for comment.**
- **One two-person team is preparing the short-term alignment revision of ISO/IEC 15288. First working draft has been distributed for comment.**
- **A fifth person serves as “alignment editor” to make sure that the tunnel meets in the middle of the mountain.**
- **Simultaneously, an integration team is developing concepts (including an agreed set of processes) for the longer-term integration effort.**
- **Formal balloting will begin circa June 2006.**
- **Alignment phase of project should complete circa June 2007.**
- **Then, we have to decide what to do about full integration of the processes.**



Abbreviations

- **Amd: Amendment [to an international standard]**
- **CMMI: Capability Maturity Model Integrated**
- **CS: [IEEE] Computer Society**
- **CSDP: [IEEE Computer Society] Certified Software Development Professional**
- **F-IEEE: Fellow Member of the IEEE**
- **IEC: International Electrotechnical Commission**
- **IEEE: Institute of Electrical and Electronics Engineers, Inc.**
- **ISO: International Organization for Standardization**
- **JTC1: Joint Technical Committee 1 (Information Technology) of ISO and IEC**
- **LC: Life Cycle**
- **SC7: Subcommittee 7 (Software and Systems Engineering) of ISO/IEC JTC1**
- **SW: Software**
- **SWEBOK: Software Engineering Body of Knowledge**
- **TCxxx: Technical Committee xxx of ISO or IEC**
- **TMB: [ISO] Technical Management Board**
- **WG7: Working Group 7 of ISO/IEC JTC1/SC7**